

46	47300250133	VITE UNI 5739 T.E. TF M10x1,5x 35 - 8.8 ZN	2
45	47300250090	VITE UNI 5739 T.E. TF M 8x1,25x 35 - 8.8 ZN	2
44	47300250087	VITE UNI 5739 T.E. TF M 8X1,25X 30 - 8.8 ZN	16
43	47300250083	VITE UNI 5739 T.E. TF M 8X1,25X 25 - 8.8 ZN	11
42	47300250078	VITE UNI 5739 T.E. TF M 8X1,25X 20 - 8.8 ZN	4
41	43505100158	TUBO OLIO MANDATA CUSC. ANTERIORE CORPO PM90T	1
40	43505100157	TUBO OLIO MANDATA CUSC. POSTERIORE CORPO PM90T	1
39	43505100156	TUBO OLIO MANDATA CUSCINETTO ANTERIORE PM90T	1
38	43505100155	TUBO OLIO MANDATA CUSCINETTO POSTERIORE PM90T	1
37	43505100154	TUBO OLIO ASPIRAZIONE PM90T	1
36.1			-
36	43505100146	SUPPORTO SUPERIORE PM90T PER SERBATOIO OLIO	1
35	43505100145	FLANGIA PORTATENUTE PM90T (L)	2
34.1			-
34	43505100162	CARTER POMPA OLIO PM90T / PM150T	1
33	43505100141	MOZZO ANT / POST PM90T (L)	2
32	43505100139	FLANGETTA TRAINO POMPA OLIO PM90T / PM150T	1
31	43504100013	COPRIVENTOLA POSTERIORE PM90T (L)	1
30.3	6.924063050-2	RACCORDO DIRITTO Ø4-1/8"	2
30.2	6.924019025-2	RACCORDO ESTREM. 90° 1/8-6"	1
30.1	6.927040006-1	POMPA OLIO DX 2 MANDATE CON GIUNTO	1
30	43503200009	KIT POMPA OLIO DX PM90T (TARATA+RACCORDI)	1
29	43505500026	LAMELLA DEC.PM80T	3
28.4	47300310583	VITE UNI 5931 T.C.E.I. M 8X1,25X 25 - 12.9 ZN-D	8
28.3	47370130032	SPINA UNI 6364 CIL. TEMP. PRATA D=10X 30 - 100CR6	4
28.2	6.611000750-1	MOZZO ANT. 1-2-3000g. AC-MAC	2
28.1	6.653400791-2	ROTORE PM80T FINITO (L)	1
28	43303100002	ASSIEME ROTORE PM90T	1
27	43105100011	FLANGIA ANT / POST PM90T (L)	2
26	43105100008	FLANGIA POMPA OLIO PM90T / PM150T (L)	1
25	6.964062002-2	MOLLA A TAZZA 20x10 2x1.1	6
24	6.963005004-2	ANELLO COMPENSAZIONE Ø80	2
23	6.931004004-2	CUSCINETTO RADIALE A SFERA 80x	2
22	6.929080000-2	VENTOLA AC	2
21	6.925070000-2	TAPPO CONICO 1/8" ESAGONO INSCASSATO	4
20	6.924063050-2	RACCORDO DIRITTO Ø4-1/8"	4
19	6.924061050-2	RACCORDO 90° Ø4-1/8"	2
18	6.922000000-1	FASCETTA RIVESTITA IN GOMMA D=7.9	1
17	6.921027065-2	ANELLO TENUTA RADIALE D=28 D=40 S=6.6.5 (BAB2SL - VITON)	1
16	6.921027058-2	ANELLO TENUTA 48x72x10 BAB	4
15	6.921003522-2	ANELLO OR 209.14x216.20x3.53 V	2
14	6.921002004-2	ANELLO TENUTA 72x40x7	2
13	6.692500020-2	VALVOLA AC3-4 (L)	1
12	6.690000342-2	MOLLA DEVIATORE AC	1
11	6.683000101-2	RONDELLA	2
10	6.680600620-1	GUARNIZIONE DEVIATORE	1
9	6.680502810-2	GUARNIZIONE COLLETTORE AC3-4	1
8	6.663300970-2	COPERCHIO DEVIATORE (ALTA PRES)	1
7	6.662400510-2	CORPO PM80T L	1
6	6.626400630-2	COLLETTORE AC3-AC4-PM80T-PM90T (L)	1
5	6.626400280-2	DEVIATORE AC3-4 (L)	1
4	6.607300580-2	TARGHETTA FRECCIA	1
3	6.602400040-2	LEVA DEVIATORE L	1
2	6.1046708-7-2	TARGHETTA X DECOMPRESSORI	1
1	6.1013393-7-2	DADO ES. M12x1,25 PF ZN	1
N°	Codice	Descrizione	Q.tà

65	6.1016817-8-2	OGIVA DI RINFORZO D=6/4	2
64	6.924023100-2	RACCORDO INTERM. 90 D.=6	1
63	43505100161	TUBO OLIO ASPIRAZIONE PLASTICA PM90T	1
62.8	6.644500000-2	FILTRO ASP. NYLON X TUBO D6	1
62.7	6.924019025-2	RACCORDO ESTREM. 90° 1/8-6"	1
62.6	6.964014007-2	ROSETTA PIANA D.=22X28X1.5	1
62.5	6.673003830-1	RACCORDO PORTAFILTRO	1
62.4	6.965022002-2	TAPPO SPIA LIVELLO OLIO 3/4"	4
62.3	6.927098056-2	TAPPO CARICO OLIO 3/4" CON SFIATO	1
62.2	43505100160	RONDELLA FISSAGGIO SERBATOIO OLIO	4
62.1	43504100017	SERBATOIO OLIO LATERALE INOX (NO FORO) PM90T / PM150T	1
62	43503100008	ASSIEME SERBATOIO OLIO INOX (NO FORO) PM90T / PM150T	1
61	43504100016	COPRIVENTOLA ANTERIORE PM90T (L)	1
60	47530070004	GOLFARO UNI2947 M12 MASCHIO ZN	2
59	47450000045	ANELLO OR - 2.5 X 93 (VITON 80 SHORE NERO)	2
58	47410040003	LINGUETTA A DISCO 6X10	2
57	47350250025	RONDELLA UNI 6593 GREMBIALINA DN= 9X32 - ZN	1
56	47350190039	RONDELLA PIANA UNI 6592 M 8 - ZN	1
55	47350180028	RONDELLA PIANA 12X18 SP=1.5 - RAME	1
54	47350130011	RONDELLA GROWER UNI 1751 M 8 - C70 ZN	29
53	47310040072	GRANO UNI 5923 PIANO M12x1,25x 30 - 45H NERO	1
52	47300340024	VITE UNI 5933 T.S.P. M 5X0,8X 16 - 10.9 ZN-DEID	5
51	47300310337	VITE UNI 5931 T.C.E.I. M12X1,75X 60 - 8.8 ZN	4
50	47300310312	VITE UNI 5931 T.C.E.I. M12X1,75X 30 - 8.8 ZN	8
49	47300310308	VITE UNI 5931 T.C.E.I. M12X1,75X 25 - 8.8 ZN	4
48	47300310116	VITE UNI 5931 T.C.E.I. M 6X1X 16 - 8.8 ZN	2
47	47300310105	VITE UNI 5931 T.C.E.I. M 6X1X 10 - 8.8 ZN	1
N°	Codice	Descrizione	Q.tà

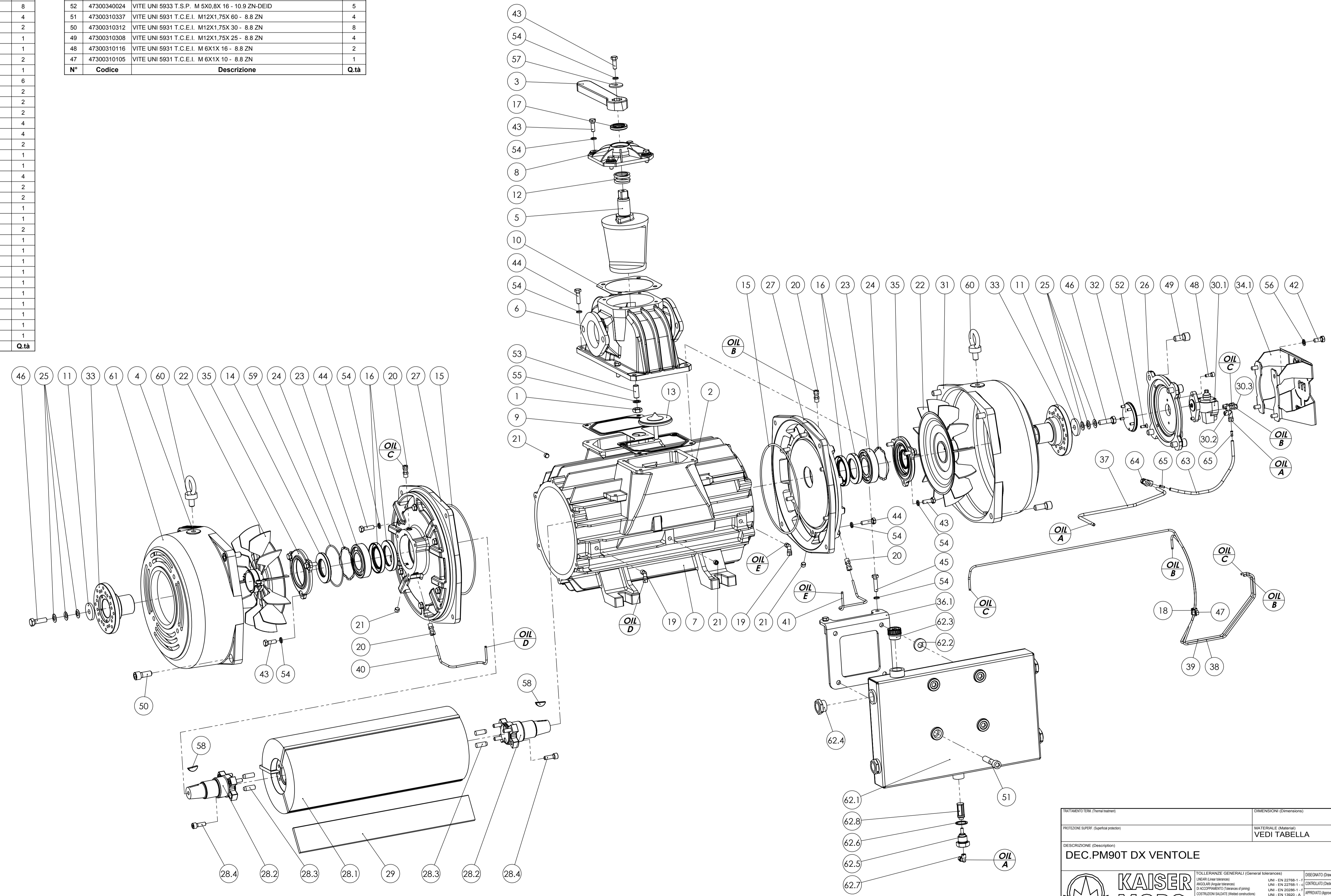

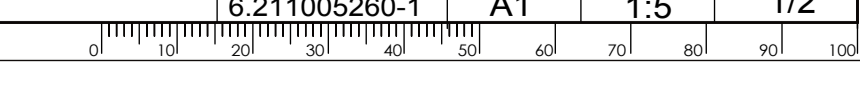

TITOLAZIONE (Title block)		DIMENSIONI (Dimensions)	
PROTEZIONE SUPER (Superficial protection)	MATERIALE (Material)	VEDI TABELLA	
DESCRIZIONE (Description)			
DEC.PM90T DX VENTOLE			
TOLLERANZE GENERALI (General tolerances)		DEGNATO (Drawn)	T. Piccolo DATA (Date) 22/10/2020
UNIF (Line thickness)	UNI - EN 22768-1	CHECKED (Checked)	P. Mio DATA (Date) 22/10/2020
ANGOLI (Angular chamfers)	UNI - EN 22768-1	APPROVATO (Approved)	G. Zille DATA (Date) 22/10/2020
RA (Surface roughness)	UNI - EN 19200-A	CONFEZIONATA (Packaging)	
CONFEZIONATA (Packaging)	UNI - EN 19200-A	CODICE (Code)	
212.345		6.211005260-1 / 00	
PUBBLICAZIONE (Publication)		SCALA (Scale)	
6.211005260-1		A1	
1:5		1/2	

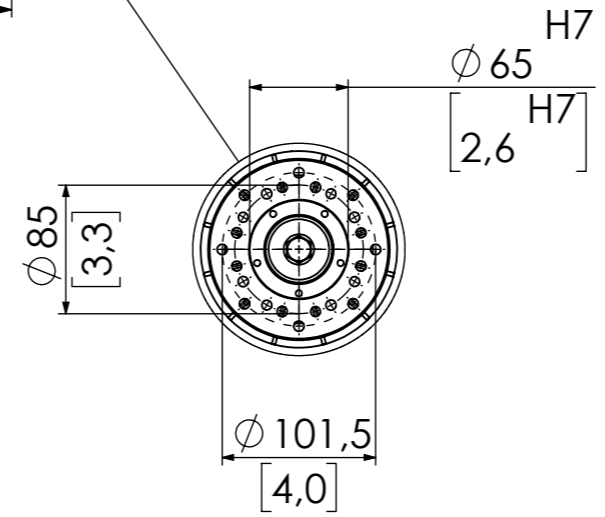
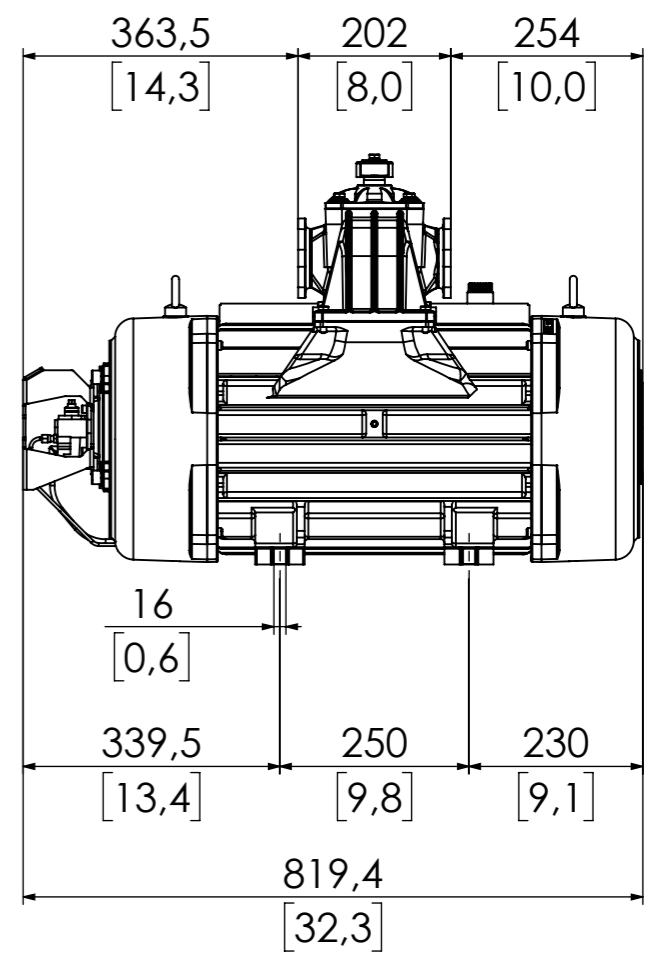
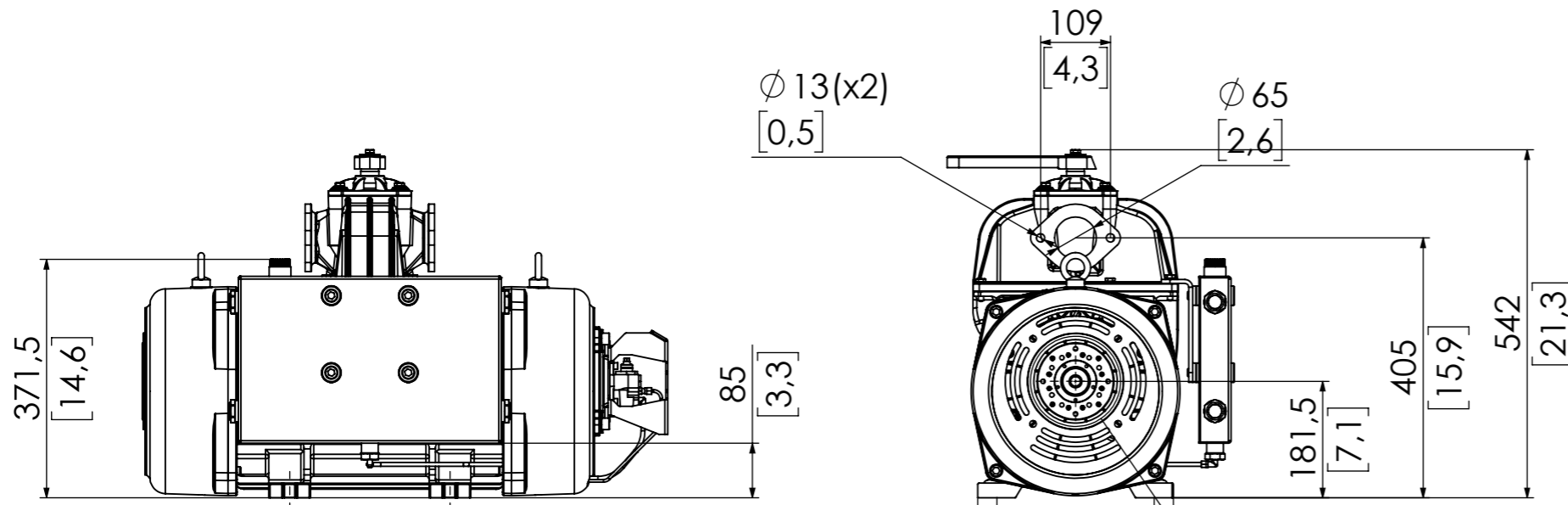

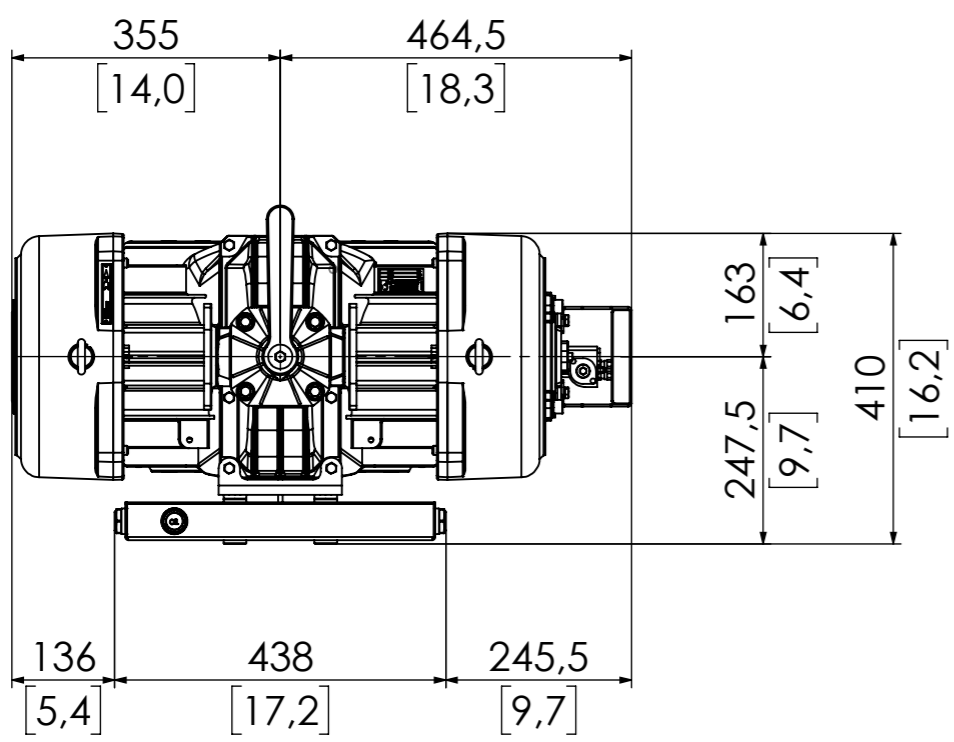

DETTAGLIO A SCALA 1 : 5



TRATTAMENTO TERM. (Thermal treatment)		DIMENSIONI (Dimensions)	
PROTEZIONE SUPERF. (Superficial protection)		MATERIALE (Material) VEDI TABELLA	CODICE MATERIALE (Material Code)
DESCRIZIONE (Description) DEC.PM90T DX VENTOLE			
 KAISER MORO	TOLLERANZE GENERALI (General tolerances)		DISEGNATO (Drawn) T. Piccolo DATA (Date) 22/10/2020 LINEARI (Linear tolerances) UNI - EN 22768-1 - f ANGOLARI (Angular tolerances) UNI - EN 22768-1 - c DI ACCOPPIAMENTO (Tolerances of joining) UNI - EN 20286-1 - f COSTRUZIONI SALDATE (Welded constructions) UNI - EN 13920 - A
	PESO GREZZO (Raw weight) kg PESO FINITO (Finished weight) kg 212,345		APPROVATO (Approved) G. Zille DATA (Date) 22/10/2020 CODICE (Code) 6.211005260-1 / 00
PROPRIETÀ DELLA MORO KAISER S.R.L. SENZA AUTORIZZAZIONE DELLA STESSA IL PRESENTE DISEGNO NON POTRÀ ESSERE COMUNQUE UTILIZZATO PER LA COSTRUZIONE DELL'OGGETTO RAPPRESENTATO NÈ VENIRE COMUNICATO A TERZI O RIPRODOTTO. LA MORO KAISER S.R.L. TUTELA I PROPRI DIRITTI A RIGORE DI LEGGE. All proprietary rights reserved MORO KAISER S.R.L. This drawing shall not be reproduced or in any way utilized for manufacturing the component or unit here in illustrated and must not be released to other parties without written consent. Any infringement will be legally pursued.		SOSTITUISCE (Supersedes) FILE No. 6.211005260-1	QUOTE DA CONTROLLARE (Dimensions to be checked) FORMATO (Form.) A3 SCALA (Scale) 1:10 RUGOSITÀ NON SPEC. (Roughness not specified) <input checked="" type="checkbox"/> Tav. 2/2

