

BRÄTSCH

KOMPRESSOREN



Reciprocating Compressors for Discharging Tankers

Specialised in Discharging Tankers

High demands are made on compressors for discharging tankers: reliable performance must always be guaranteed - regardless of which charging media is filled. Furthermore, the compressor must be compact and easy to mount. We have therefore developed the robust BRAETSCH reciprocating compressors that have been specially designed for the discharging of liquids such as chemicals, bitumen, low gravity oil, and food out of tankers.

BRAETSCH KOMPRESSOREN

Technical Characteristics:

- Compact dimensions
- Low weight
- Drive: cardan shaft, hydraulic motor, or e-/ diesel/ engine
- Flexible rotating drive direction
- Alterable position of air inlet and pressure outlet
- Variable attachment and flexible mounting
- Non-corrosive materials
- Efficient cooling system
- Oil-free and oil lubricated versions
- Available for 4.5 bar, 8 bar or 10 bar
- Suitable for vacuum compression applications

Short Discharging Periods

The compressor capacity and volume flow rate are synchronised exactly, which leads to great performance.

You have surely experienced the same: Some compressors run hot on higher pressure and consequently turn off. This will never happen with a BRAETSCH compressor.

The discharging runs with 2.5 bar; though the compressor is laid-out for 4.5, 8 or 10 bar.

A BRAETSCH compressor even runs very reliably under extreme conditions, for example when discharging high viscosity media (resin) and pressure in high altitude tanks.

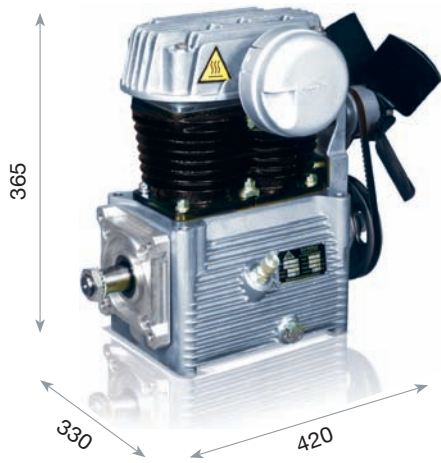

K2 - 500

air delivery 400 l/min	max. vacuum 0,8	amount of cylinders 2
max. working pressure 10 bar	motor size 3 kW	cylinder stages 1
max. r.p.m. 1.650 min ⁻¹	weight 27	oil-free lubrication no

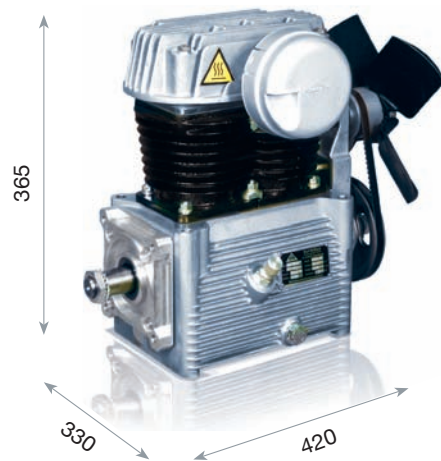

K2 - 600

air delivery 500 l/min	max. vacuum 0,8	amount of cylinders 2
max. working pressure 8 bar	motor size 3 kW	cylinder stages 1
max. r.p.m. 1.650 min ⁻¹	weight 26 kg	oil-free lubrication no

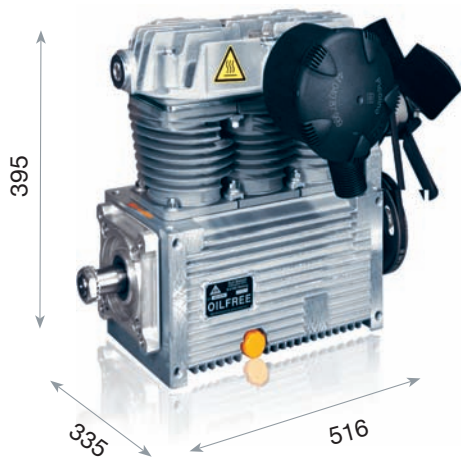

K3 - 1275 oilfree

air delivery 1.000 l/min	max. vacuum 0,8	amount of cylinders 3
max. working pressure 4,5 bar	motor size 4,5 kW	cylinder stages 1
max. r.p.m. 1.650 min ⁻¹	weight 27 kg	oil-free lubrication yes

Low Life Cycle Cost

BRAETSCH compressors are characterised by a more than average life span. Especially the oil-lubricated compressors often reach a product life of several decades. You thereby protect yourself from unplanned new expenditures.

BRAETSCH reciprocating compressors satisfy their owners with their slow wear out and therefore low maintenance costs. In comparison to vane compressors, you save

yourself the laborious changing of the vanes. If parts should fail nevertheless, the reciprocating system is easy to repair and known in all garages. Moreover, spare parts are always on stock, independent from serial numbers.

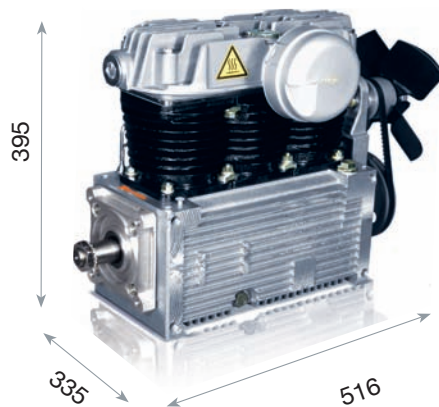

K3 -1300

air delivery 1000 l/min	max. vacuum 0,8	amount of cylinders 3
max. working pressure 4,5 bar	motor size 5,5 kW	cylinder stages 1
max. r.p.m. 1.650 min ⁻¹	weight 38 kg	oil-free lubrication no

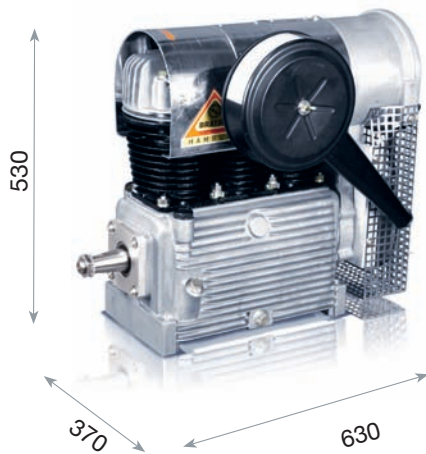

K3 - 2399

air delivery 2000 l/min	max. vacuum 0,8	amount of cylinders 3
max. working pressure 4,5 bar	motor size 9 kW	cylinder stages 1
max. r.p.m. 1.650 min ⁻¹	weight 70 kg	oil-free lubrication no

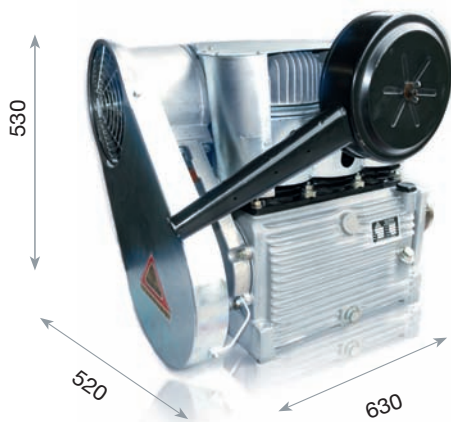

K3 - 2400

air delivery 2.000 l/min	max. vacuum 0,8	amount of cylinders 3
max. working pressure 8 bar	motor size 11 kW	cylinder stages 1
max. r.p.m. 1.650 min ⁻¹	weight 83 kg	oil-free lubrication no

Low Mounting Costs

Thanks to its small size, the BRAETSCH reciprocating compressor can be mounted from various positions – even overhead if you want (oil-free compressor).

The outlet temperature is so low that you can use flexible pressure hoses so that you do not have to install additional conduits.

Reliable Operation

Those looking for a compressor can choose between the low-cost vane compressor system and the robust reciprocating technology. At BRAETSCH we have always focused on reciprocating compressors because they exhibit a much longer product life. In comparison to vane compressors, the reciprocating models are not influenced by possible stagnancy, high loads or temperature oscillation - a BRAETSCH reciprocating compressor runs undisturbed.

Accessories & Compressed Air Conditioning

In addition to our compressors we also offer the full range of compressed air equipment, filters, mounting-kits as well as customised solutions. Let's see together what we can do for you.

BRÄTSCH KOMPRESSOREN



**Check Valve
Safety Valve & Glycerin
Pressure Gauge**



Micro Filter



Adsorber



Fine Filter



Separator

Standard Accessories

- Check valve, safety valve, and glycerin pressure gauge (already pre-installed on a untrimmed carrier)
- Separator
- Flexible pressure hoses
- Fastening bolts

Customer-Specific Solutions

Would you prefer something more individualised? For company-specific requirements, we are also happy to develop a complete built-in solution incl. a cardan shaft.

Compressed Air Condition

- Fine filters, Micro filters
- Adsorbers – Sterile filters

Made in Germany

Competence from Experience

Compressors are not only our work, but also our passion – for several generations. Since 1945, our Hamburg family business has been developing and producing compressors, making us one of the oldest and most experienced producers of built-in compressors in Europe.

Customised Product Development

Our product and service range includes compressors, aggregates, and compressed air systems as well as compressed air conditioning and corresponding accessories. Customers from the workshops, industry, and the segments diesel starter air, discharging tankers, and vehicle manufacturing trust in the proven Braetsch quality. Whether you would like to choose from our standard product range or whether you prefer to turn your company-specific requirements into a customised series or single production, we always react flexibly to all your needs because customer orientation is our first goal.

Short Delivery Periods

If you not only set a high value on quality made in Germany and high product life cycle but also on short delivery periods, you will be pleased with our one-day delivery rule: Whatever you order by 3 pm will usually be delivered to you the next morning. We provide a pan-European dealer and service network and thus offer a supraregional spare parts service and an uncomplicated exchange service for compressors.

Modern Innovation Power

The high standards that we apply for our products and our services also go for our personnel management. We thus have a very low employee turnover, from which our customers benefit. Additionally, years of experience positively influences the product development and creates capacities for innovation. Our cooperation with several universities and research institutes combines constant quality with technical innovation power.

BRÄTSCH
KOMPRESSOREN

Kurt-A.-Körper-Chaussee 39d
Germany - 21033 Hamburg

Fon: +49 (0)40-7213818

Fax: +49 (0)40-7216986

Email: info@braetsch.de

Web: www.braetsch.de