

RevNo	Revision Note	Date	Signature	Checked
-------	---------------	------	-----------	---------

ITEM	PRODUCT CODE	DESCRIPTION	QUANTITY
1	AAC15E/12	After air cooler 12V blowing	1
2	AAC15E/24	After air cooler 24V blowing	1

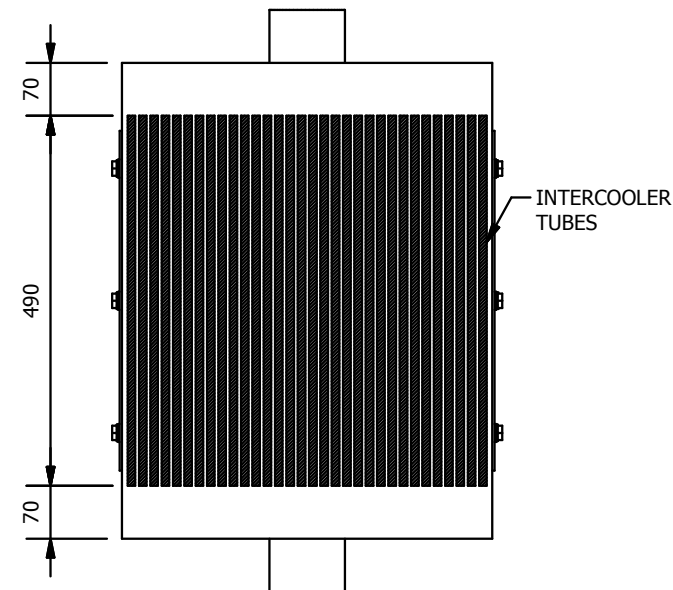

SCALE	1:10	DATE
DRAWN	MM	29/10/2015
CHECKED	DR	29/10/2015
AUTHORISED	PW	29/10/2015

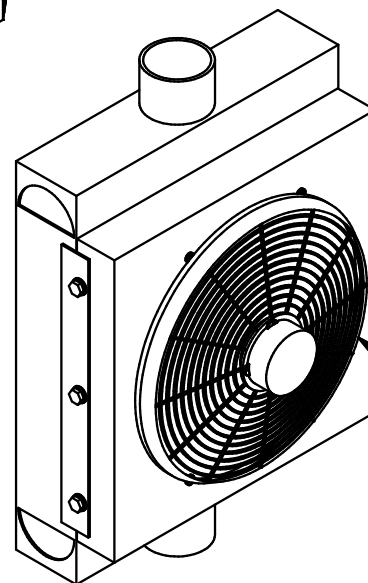
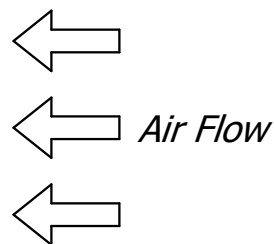
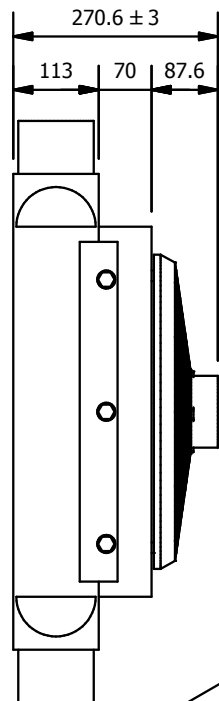
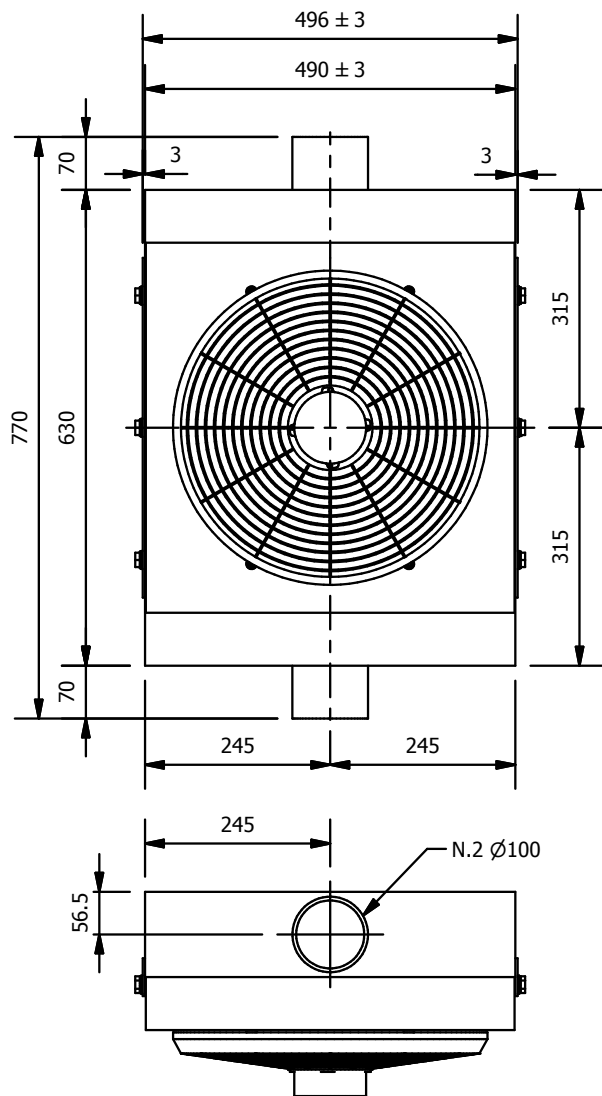

Unit 28 Croft Road Industrial Estate,  
Newcastle, Staffordshire, ST5 0TW.  
Tel: +44(0)1782 710282  
Fax: +44(0)1782 710126

TITLE

**AAC15E AFTER AIR COOLER**

DRG No **TAV.03.1.005**

REVISION

A

SHEET

1 OF 1