

T155 COMPRESSOR

The next generation of Compressors for liquid tanker pressure discharge

This is a contactless liquid tanker compressor, giving unparalleled performance in a virtually maintenance free unit. The compressor is available with hydraulic drive, making it adaptable to position on limited space tractor units.

The T155 uses the hook and claw principle to generate 2.5 Barg pressure. This delivers real performance with first class reliability.

Product features

- Contactless oil free (no vanes)
- Precision engineered
 - Virtually maintenance free
 - Low noise – 90 dB(A) @ 1m
 - Optimal discharge times
 - Air cooled
 - Oil free

Only available

- Hydraulic drive

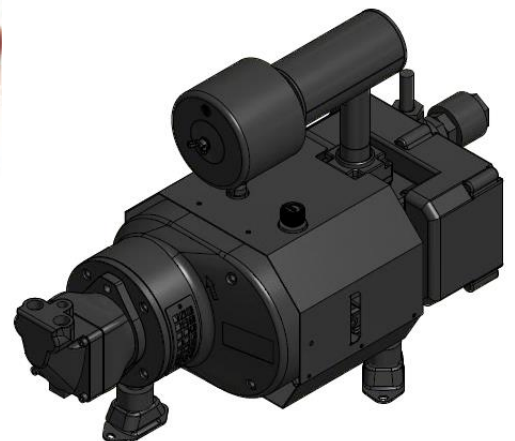

TRANSAIRVAC
INTERNATIONAL LTD

www.transairvac.com

T155 COMPRESSOR

TECHNICAL SPECIFICATIONS

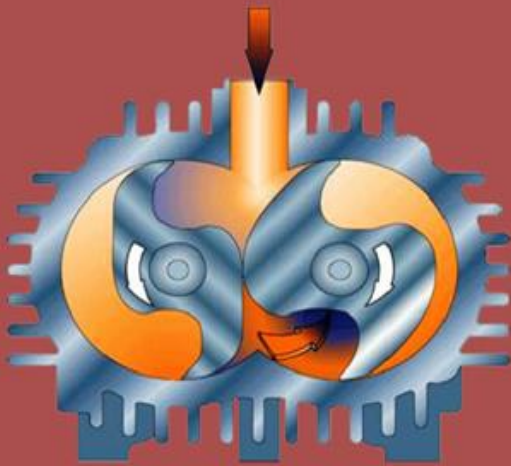

Performance

Flow Range	Pressure	Speed	Absorbed Power at 2.5 Barg
m ³ /hr	bar	rpm	kW
150	2.5	3000	9.5
180	2.5	3600	10.8

FEATURES

- Contactless (vane free) compressor
- Oil free
- 2.5 Barg continuously rated
- Air Cooled
- Low maintenance
- Low noise 90 dB(A) @ 1m
- 150 – 180 m³/hr
- Bare shaft unit 110 kg
- Hydraulic drive

Available complete on a frame ready to mount on the chassis.



T155 Dimensions Weight: 110kg

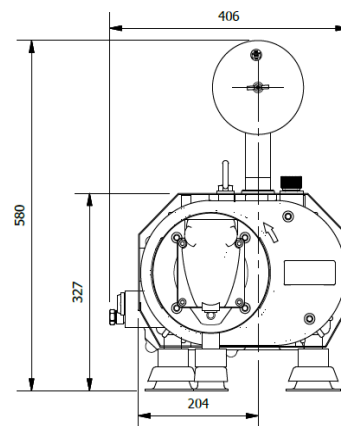
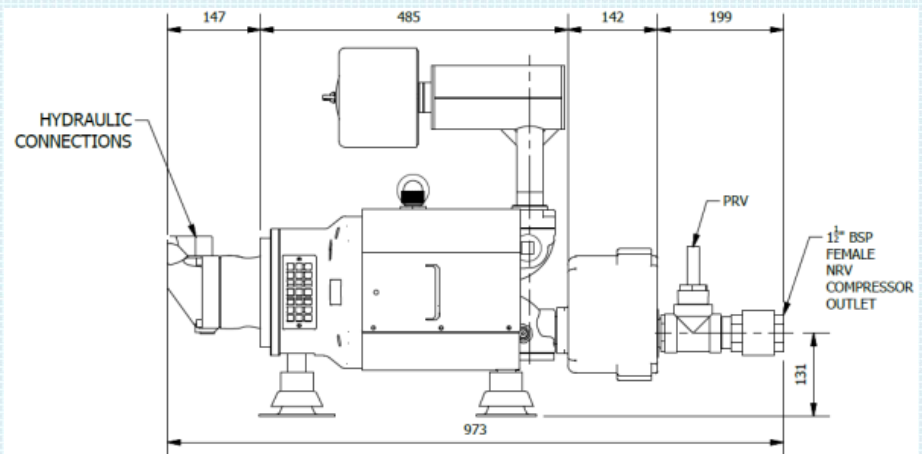

Other Transairvac products include:

- Hydraulic coolers
- Pressure line filters
- Compressors
- Vacuum pumps
- Blowers
- Rotary lobe pumps

TRANSAIRVAC
INTERNATIONAL LTD

Units 28, Croft Road Industrial Estate, Newcastle,
Staffordshire ST5 0TW

Tel: +44 (0)1782 710282 Fax: +44 (0)1782 710126

email: office@transairvac.com

web: www.transairvac.com