

RevNo	Revision Note	Date	Signature	Checked
-------	---------------	------	-----------	---------

Item	Product Code	Description	Quantity
1	HC16	Cooler without motor	1
2	PARMM-32-32	2" male x 2" male union	1
3	HC14/19	2" BSP female x 2" 90' hose tail	1
4	PARDSSC-32	2" Bonded seal	2
5	PARMP-32	2" BSP Stainless steel plug	1
6	PARMM-16-12	1" BSP Male x 3/4" BSP Male Union	1
7	PARMP-16	1" BSP Stainless steel plug	1
8	PARDSSC-400-830	1" Bonded seal	3
9	FAN.12.12.B	12 volt DC fan 12" (optional)	1
10	FAN.12.24.B	24 volt DC fan 12"	1
11	HC14/2	Oil level gauge (One each side)	2
12	HC20/1	Temperature switch 60-48°C (Optional)	1
13	BREATHER. 5	1/2" BSP Breather	1
14	HC15/13	1" BSP Male X 3/4" BSP Female reducing bush (optional)	1
15	PARDSSC-08	1/2" Dowty Washer	1
16	PARMP-08	1/2" Male Plug	1

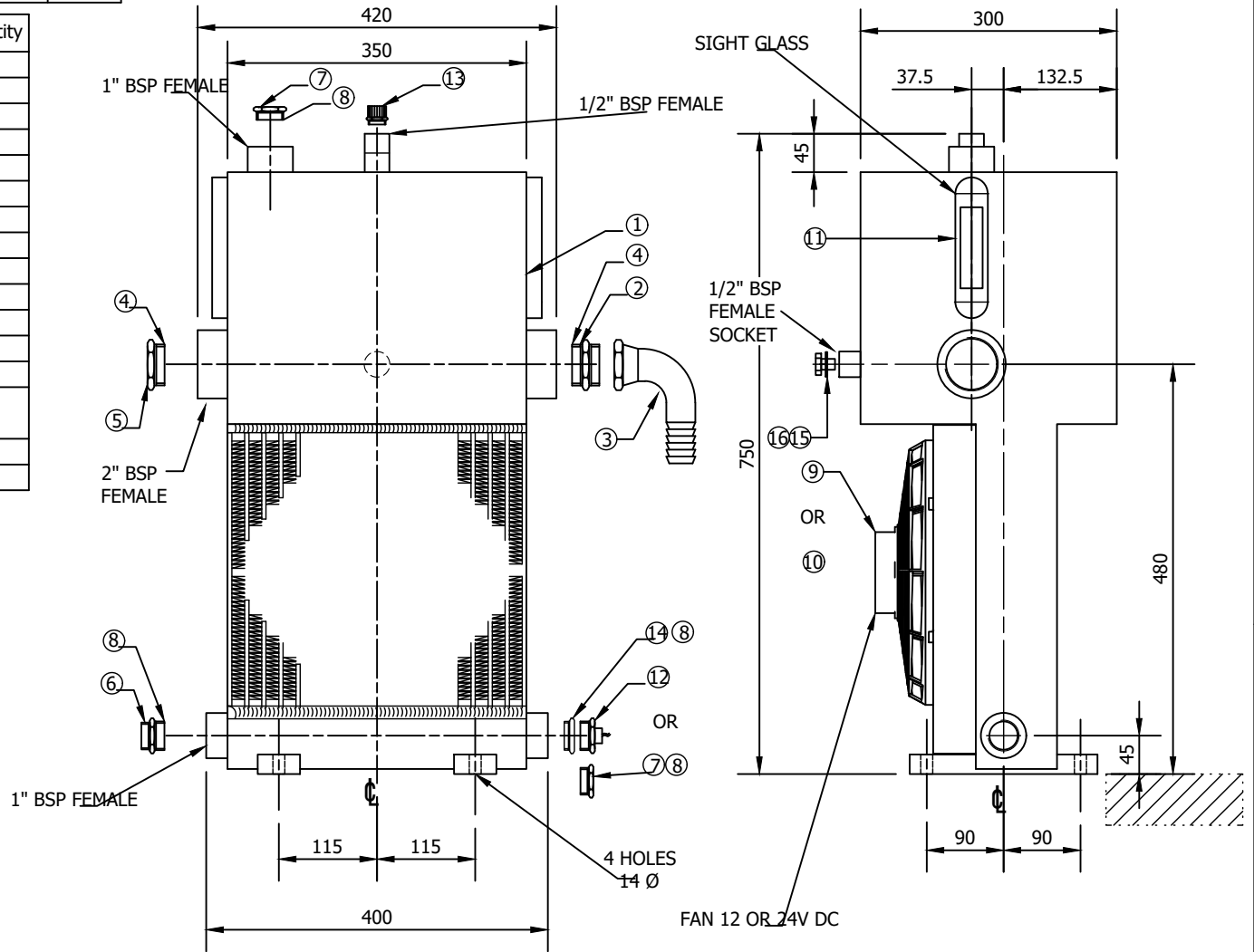

GEN TOLERANCE: ±2mm

TANK CAPACITY 20 LTR

PART REF No		
HC 16/02		
SCALE	1:6	DATE
DRAWN	CADMAN	25/02/2022
CHECKED	DR	.
AUTHORISED	MH	.

TRANSAIRVAC
INTERNATIONAL LTD

Unit 28 Croft Road Industrial Estate,
Newcastle, Staffordshire, ST5 0TW.
Tel: +44(0)1782 710282
Fax: +44(0)1782 710126

TITLE		
HC16 ASSEMBLY DRAWING		
DRG No	TAV.03.10.002	REVISION
		2
		SHEET
		1 OF 1