

PLF 150 FILTER

*High quality filter industry approved performance
(5 micron absolute)*

Liquid Tanker Filter is an industry approved filter. It has excellent pressure drop characteristics and has a high dirt holding capacity

Giving you the adaptability you need

There are optional grades of filtration available

Product features

- Fully, stainless steel body
- Pleated stainless steel fibre element
- Gauge points
- Drain points

Options

- Other grade of filtration (40 micron)



www.transairvac.com

PLF 150 FILTER

TECHNICAL SPECIFICATION

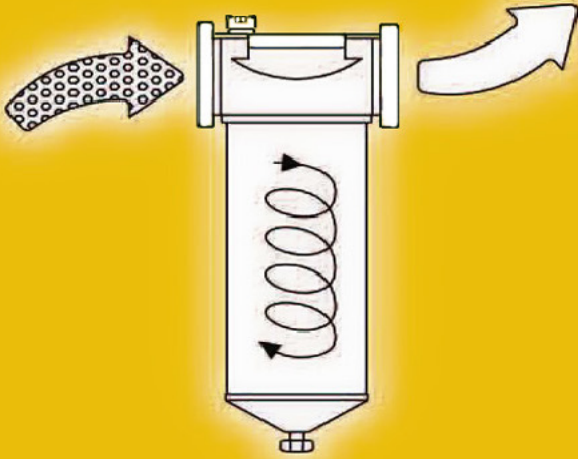

PLF 150

Flow rate m ³ /hr	20 – 180 m ³ /hr
Temperature rating	-30°C to +180°C
Filtration Efficiency	5micron absolute 100% 1micron @99.5%
Pressure rating	3barg rated 10 bar max

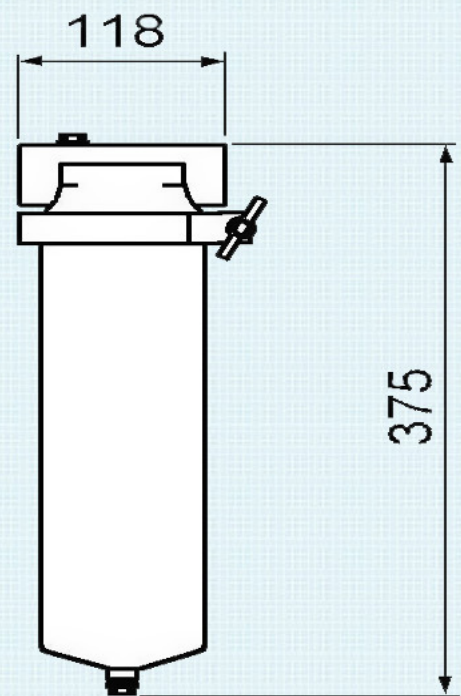

Filter options

- 40 micron element

PLF1000



Hiflow



Elements manufactured to customer specification



Other Transairvac products include:

- Hydraulic coolers
- Pressure line filters
- Compressors
- Vacuum pumps
- Blowers
- Rotary lobe pumps



Units 12 – 17, Croft Road Industrial Estate,
Newcastle, Staffordshire ST5 0TW
Tel: +44 (0)1782 710282 Fax: +44 (0)1782 710126
email: office@transairvac.com
web: www.transairvac.com