



*Hydraulic Coolers, Pressure Line Filters, Air & Gas Compressors / Vacuum Pumps / Blowers
/ Booster Packages and Rotary Lobe Pumps for Transport and Industry.*

“HC 24”

HYDRAULIC OIL COOLER

INSTALLATION, OPERATION & MAINTENANCE MANUAL



Transairvac International Ltd, Units 28 Croft Road Industrial Estate, Newcastle-Under-Lyme, Staffordshire,
England . ST5 0TW, Telephone: 0044 (0)1782) 710282, Fax: 0044 (01782) 710126

Email: office@transairvac.com Web page: www.transairvac.com

Contents

1 GENERAL INFORMATION

2 HEALTH AND SAFETY

3 GENERAL INFORMATION AND SAFETY STANDARDS

3.1 Responsibility for use

3.2 Safety standards

3.2.1 Assembly

3.2.2 Lifting

3.2.3 Positioning

3.2.4 Insulation

3.2.5 Working station

3.2.6 Fire risks

3.2.7 Object projection

3.2.8 Environmental pollution

3.2.9

Hydraulic Circuit Diagram

Parts List

Over all dimensions & specification

4 INSTALLATION

4.1 Operating principle and unit composition

4.1.1 Accessories

4.2 Starting-up the system

4.2.1 Checking the tank

4.2.2 Filling the tank

4.2.3 Recommended oils

4.2.4 Connection

4.2.5

4.3 Operating the system

4.3.1 Operators

4.3.2 Before operating the system

4.4 System operation

MAINTENANCE

4.5 Foreword

4.6 Maintenance of main components

4.6.1 Hydraulic oil change

4.6.2 Oil Filter on Delivery* (optional — documentation upon request)

4.6.3 Oil Return Line Filter

4.6.4 Filler Cap

4.6.5 Air-oil heat exchanger

4.7 Maintenance intervals

4.7.1 Standstill

4.7.2 Troubleshooting

1 General Information

To ensure immediate advice on your cooler, and for your own records the following information should be noted:

TYPE:.....HC.24COOLER.....

SERIAL No: [S] ..TAV.....

VEHICLE DETAILS .(Reg/number).....

DATE OF SUPPLY

CONTRACT NUMBER:

CUSTOMER NAME:

This information will be required should you need further information or parts ordering.

2 HEALTH AND SAFETY

Rotating machinery and pressurised components are potentially dangerous items of equipment if not properly operated and maintained. It is imperative that all users of such equipment fully educate themselves as to the potential dangers and satisfy themselves that the personnel responsible for installing, testing, commissioning, operating and maintaining the machinery are competent to do so. Instruction manuals are provided for guidance but must assume some basic level of competence by user staff. If there are any doubts concerning correct procedures, ask Transairvac International Ltd., who will be pleased to advise, or provide a service engineer. **DO NOT TAKE RISKS.**

The following, whilst not exhaustive, provide guidance to possible sources of danger to health and safety:

Certain machinery can generate high levels of noise which can be harmful to people exposed to it for lengthy periods of time. Various recommendations and codes of practice are in existence and users must ensure that adequate precautions are taken to prevent a health hazard to employees or third party.

Before attempting to investigate problems, service or maintain equipment, it must be safely depressurised to ambient conditions.

Moving parts of machinery must not be touched and must be adequately guarded. Suitable guards are provided and must be securely retained in position at all times except when maintenance or service is being undertaken. Before commencing maintenance, servicing or making other adjustments, the prime mover and other equipment must be isolated to prevent accidental start-up.

Most machines, certain pipes and ancillaries become hot during operation. If it is possible for personnel to come into contact with such surfaces unknowingly or accidentally they should be guarded.

If, during operation, severe vibration is observed on the compressor it's prime mover, pipework, or ancillaries, the cause of this should be immediately investigated and the situation rectified. Excessive vibration can lead to fatigue and other failures. Similarly, if during operation a significant change is noticed in the level of vibration, noise, temperature or any other parameter, the cause of such changes must be determined, and the cause rectified.

When maintaining equipment, contact will be made with potentially corrosive substances. Care must be taken not to ingest any of these and to protect skin. Only approved lubricants must be used.

After completion of servicing, all nuts, setscrews, etc must be checked for tightness. Before restarting after servicing, check all joints, are tight. Also, before any start-up, check that the machine inlet and outlet isolating valves are open and the system can work safely.



**PERSONAL
PROTECTIVE
EQUIPMENT
THAT MUST
BE USED**

3 GENERAL INFORMATION AND SAFETY STANDARDS

TransAirVac International Ltd. reserves the right to make changes and improvements to its units at any time without previous notice, and is not liable for any difference existing between the unit features and the descriptions in this manual. This manual is a guide for the correct use of the Cooling Unit and for maintenance the efficiency of the unit through correct regular maintenance. After having fully read this manual, it is recommended that it be kept near the machine to facilitate immediate reference.

CAUTION: In case of doubts or problems in understanding this manual or parts of it, Or for any kind of technical information please contact TransAirVac International Ltd.

3.1 Responsibility for use

This cooling unit must be considered as a sub-assembly and it is therefore the installer/users exclusive responsibility to make sure that the final system of which this component represents a sub-assembly is equipped with the suitable safety devices (prv etc) . Moreover, TransAirVac International Ltd. expressly prohibits the commissioning of this unit before the complete system conforms to the prescriptions of directive 98/37 EC and following amendments. Only suitably trained and qualified personnel must use this system.

3.2 Safety standards

Before using this unit, carefully read this operation and maintenance manual.

3.2.1 Assembly

TransAirVac International Ltd. recommends the use of hoses and pipe fittings of adequate size and to observe the assembly instructions supplied by their supplier. 2" suction pipe work , and min 3/4" return .

3.2.2 Lifting

The unit must be only be lifted by qualified and trained personnel. It is absolutely forbidden to use piping or other unit components as lifting points.

3.2.3 Positioning

The cooler must be positioned in such a way that its stability is ensured; on this respect it is necessary to arrange the possible use of anti-vibration connections or suitable bases as it is an air blast cooler then keep away from heat sources or the hot air from the main engine system.

3.2.4 Insulation

In the complete system in which this unit is used hydraulic system must be duly insulated against possible sources of vibrations. Vibrations represent a danger because they can cause a progressive loosening of the pipefitting and, as a consequence, the possible leak of fluid under pressure. We therefore recommend using anti-vibration devices and flexible pipe work.

3.2.5 Working station

During the operation of this unit, inspections near the components under pressure or any components through which oil passes are forbidden. It is also forbidden to intervene on moving parts if the general power supply has not been previously switched off.

3.2.6 Fire risks

We recommend the maximum caution while using devices under pressure: The piping which are near heat sources (exhaust manifolds, mufflers, etc.) must be duly protected to prevent oil splashes from coming into contact with them, thus initiating possible fire principles.

3.2.7 Object projection

It is up to the installer to arrange suitable shields near hoses of those system points that are subject to especially high pressure and not to remove the devices protecting rotating parts.

3.2.8 Environmental pollution

During the oil change or other maintenance intervention, **DO NOT DISPOSE OF OIL IN THE ENVIRONMENT**, but arrange its disposal correctly.

HC24 Cooler

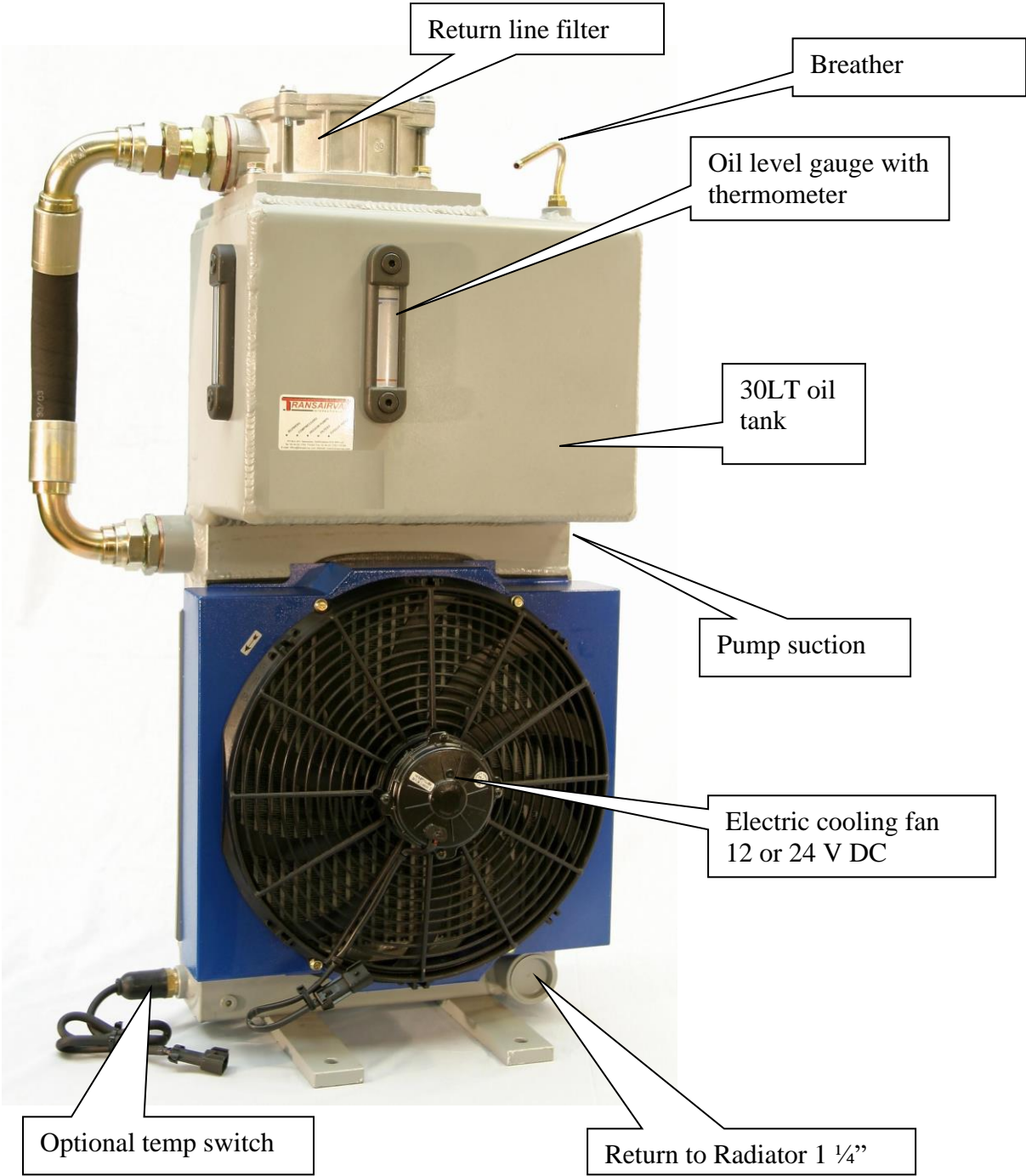

Hydraulic Circuit Diagram

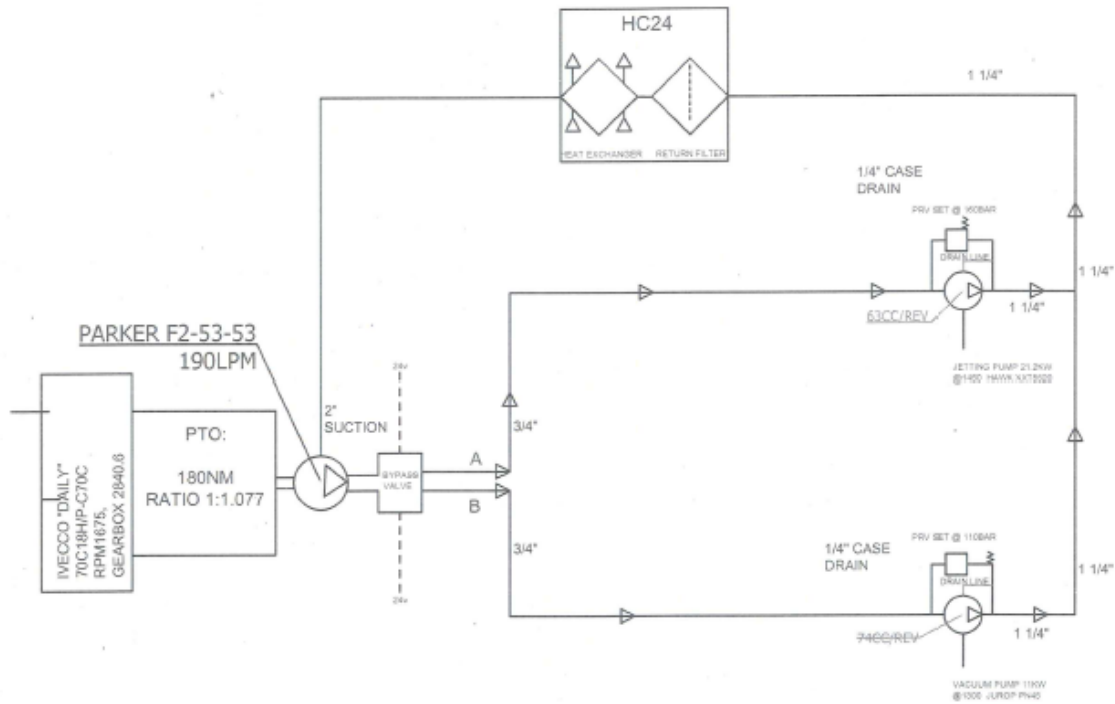

PARTS LIST HC 24

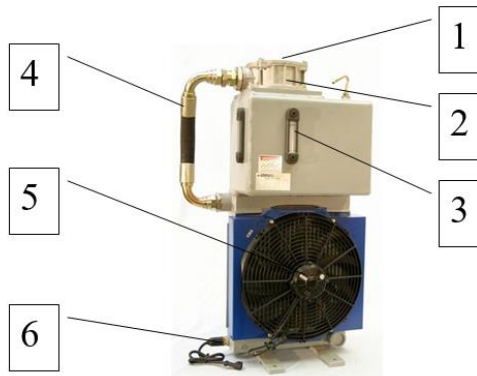

Item	Part number	Description
1	HC.24/1	Filter restriction Indicator
2	HC.24/2	Return line filter complete
	HC.24/3	Replacement Filter Element
	HC.11/4	"O" Ring kit (3 Pcs)
3	HC.14/2	Sight Glass each (2 on cooler)
4	HC.24MTAD	Return hose assembly
5	AAC.15/4	Electric Fan 24 volt
	AAC.15/2	Electric Fan 12 Volt
6	HC.20/1	Temperature Switch

OVERALL DIMENSIONS OF HC16

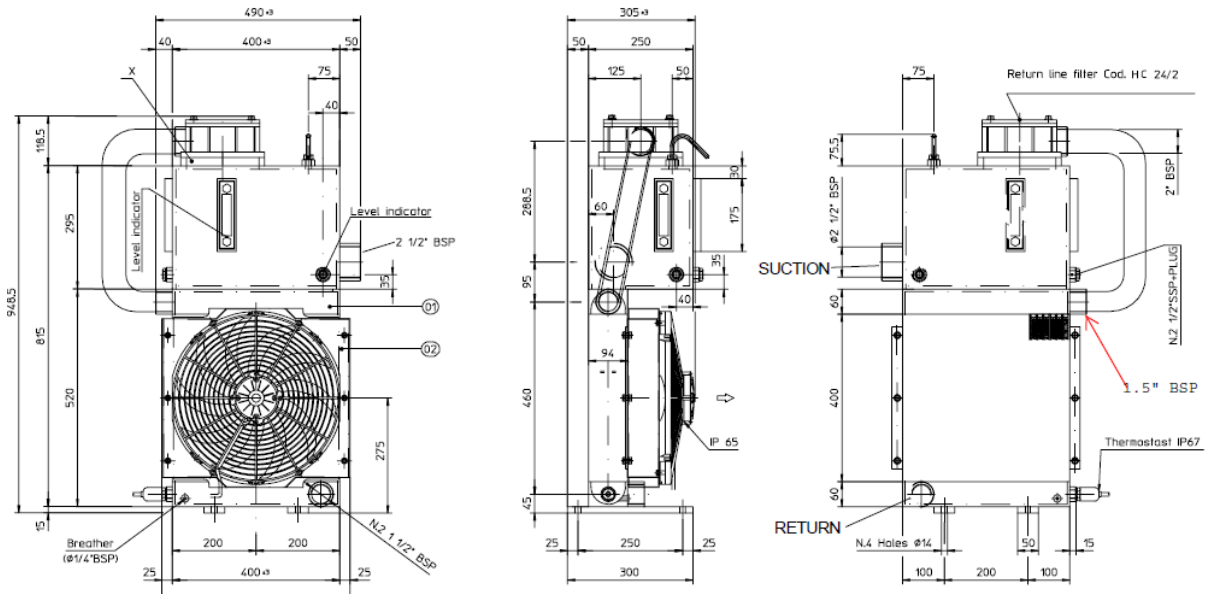

TECHNICAL SPECIFICATION

HC. 24 SPECIFICATION	
Hydraulic Flow	From 80 To 200 Litres Per Minute
Hydraulic Pressure	Max return line pressure 20 bar
Fan Motor Speed	2,320 rpm
Heat Dissipation	23.5 kW
Oil Tank Capacity	30 Litres
Fan motor	12 or 24 V DC

4 Installation

4.1 Operating principle and unit composition

The cooling unit operates by means of passing the hot oil from the drive system through a heat exchanger cooler matrix which is air blast cooled from the close coupled electric fan .

The oil is then stored in the tank on top of the radiator matrix and piped to suction of a suitable hydraulic pump .

4.1.1 Accessories

These include a thermostatic switch mounted on the cooler as an option to operate the fan motor and cut it in and out dependent on oil temp. The switch is available as an option and has two settings 47C (NO or NC) and 90C (usually used as warning of high temp)

4.2 Starting-up the system

4.2.1 Checking the tank

Visual inspection of the tank is recommended before filling with clean filtered hydraulic oil.

4.2.2 Filling the tank

As the hydraulic oil is the fluid through which power is conveyed and transmitted, it is of fundamental importance that it is of good quality.

While filling the tank, we recommend to use a filter with 25 microns. To carry out the filling, it is necessary to unscrew the filler cap, fill through this duct making the oil reach the tank until the visual level indicator signals the maximum level. At the end of this operation, insert the loading plug by repositioning it in the correct way. To change the oil, unscrew the lower plug, empty the tank and let the oil flow out collecting it in a container.

NOTE: At the first starting-up, the hydraulic oil is pumped into the system, therefore the tank level can decrease a lot. Carry out a suitable re-filling (with unit at a standstill).

CAUTION: During the filling operations, observe a strict cleaning in order to avoid the contamination of the hydraulic fluid.

Suggested to fill system via return line filter , by removing the top cover and pouring through the filter.

4.2.3 Recommended hydraulic filling oils

In this system, the oil is the means that power is transmitted, ensures the lubrication and protection of the system devices; therefore we recommend using hydraulic oil with anti-foam and anti-oxidation additives. Below is a quality classification of the mean viscosity-temperature curves of oils according to two viscosity categories specified in the table on the right:

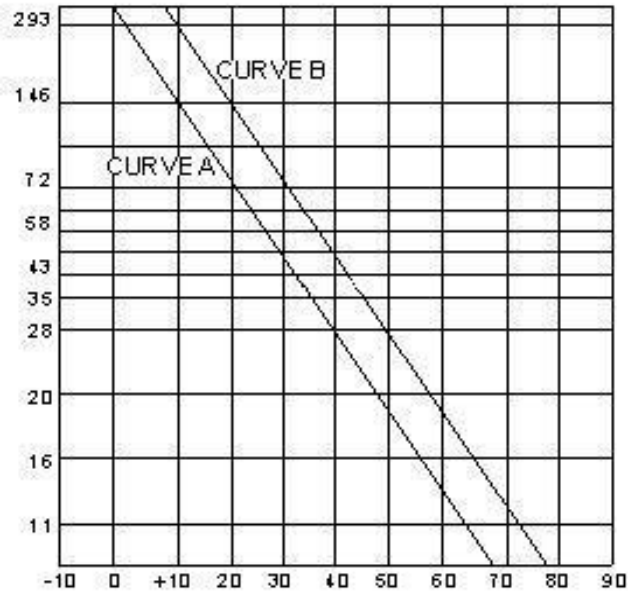

CURVE	A	B
ISO	VG32	VG46
Spec. DIN 51524	H-LP32	H-LP46
Viscosity mm ² /s cSt @50°C	16-20	24-28
AGIP	OSO 32	OSO 46
IP	Hydrus 32	Hydrus 46
BP	Energol HLP 32	Energol HLP 46
CASTROL	Hyspin AWS 32	Hyspin AWS 46
ESSO	Nuto H 24	Nuto H 46
MOBIL	DTE 24	DTE 25
SHELL	Tellus 32	Tellus 46
CHEVRON	EP Hydraulic Oil 32	EP Hydraulic Oil 46

Viscosity mm²/s(cSt) vs temp C

Taking into account that the optimal use conditions for the system are those in which the oil viscosity is between 15 to 30 mm²/s (cSt) in operating conditions, from the reported tables it is possible to determine the most suitable oil category and to choose between the proposed brands (not binding).

4.2.4 Connection

The piping connection must be carried out only by using flexible hoses correctly pressure rated.

2" or 1.5" pump suction and 1" or 3/4" return .

4.3 Operating the system

4.3.1 Operators

When operating the system, a qualified operator must be present.

4.3.2 Before operating the system

Before operating the system, make sure that the tank is full with oil up to the maximum visible outer level and that all piping are tightened in the suitable way and it is safe to operate.

Check the electrical connection to the fan and the complete hydraulic circuit.

4.4 System operation

The hydraulic oil cooler is a component part of the system and should be filled to the correct level before start up. The fluid level in the tank will decrease when filling the entire system and will need checking on start up.

Maintenance

4.5 Foreword

A hydraulic system installed in the correct way, connected and started up following the given indications ensures a long duration and only needs simple maintenance works. The operating fluid that has the important task of transmitting power is among the main causes for *out-of-service*. To help prevent problems the oil should be replaced yearly, but checked on a daily basis.

4.6 Maintenance of main components

The main component of a hydraulic system for regular maintenance is the return filter which should be changed when dirty, this will protect the main system components and give a long service life. It is important to ensure that the maintenance interventions are carried out in a clean environment and in the absence of dust. If it is necessary to remove temporarily some components like for instance pumps and distributors, they must be protected by closing their connections with protection plugs that must be removed up to their re-connection of the same to the system.

4.6.1 Hydraulic oil change

The change of the hydraulic oil should be done @ 2000 working hours or when contaminated. Use the same type of oil as originally used in system, if that is not possible the complete oil system must be drained and refilled with new oil of suitable grade etc, the interaction of chemically different fluids will be avoided, which can cause changes of the physical and functional features of the mixture.

4.6.2 Oil Return Line Filter(separate item not on cooler)

It is located on the return line and has the task of eliminating some contaminant particles contained in the oil before returning to tank. This is very important to change when required.

4.6.3 Filler Plug

It is located on the upper part of the cover and ensures a protection against foreign particles entering the system during its operation and used to top up the cooler if required.

4.6.4 Air-oil heat exchanger

- Clean radiator on discovery of dirt.
- If you notice vibrations when running the unit, a common cause is dirt on the fan blades, which makes the fans unbalanced. To rectify the situation it is necessary to clean the fan blades or if necessary remove the fan to do this or replace if damaged.

4.7 Maintenance intervals

Below is a proposal of the recommended maintenance intervals to maintain efficiency and grant its duration in time, protected against early wear :

COMPONENT MAINTENANCE	Every day	Every week	Every month	Every 500 working hours	Every 2,000 working hours
Oil filter check gauge		X			
Oil filter replacement				X	
Oil level check	X				
Oil change					X
Radiator cleaning				X	
Outer cleaning				X	

4.7.1 Standstill

In case the system is not used for long periods of time, it is necessary to check the system as initial start but also to start the system slowly and monitor it.

When re-starting the unit, observe the instructions as for the system starting-up.

4.7.2 Troubleshooting

Analysis of the possible causes of some problems and intervention hypothesis can be viewed on next page.

	Problem	Possible causes	Intervention hypothesis
A	Low system pressure	Pressure relief valve opening early	low setting
			Seal seats worn
			Impurities under the seal seats
			Spring broken
		Defect pump	See point
Component leaks	Worn seats in the cylinders or hydraulic motors		
	Valves and distributors worn		
	Oil viscosity too low		
B	Low system flow	Obstructed pump suction	Obstructed suction pipe
			Suction pipe too small or with too twisted path
		Air in the hydraulic circuit	Air in the suction intake of the tank
			Air in the suction connections
			Air in the seal on the pump shaft
			Suction of oil with foam
		Pump speed	Check the coupling
			Speed too high or too low
		Oil viscosity too high	Check grade of oil
		Pump internal failures	Broken inner seals
Glued vanes, washers or pistons			
Service or replace pump			
C	Pump noise	Cavitation	Obstructed suction pipe
			Oil Viscosity too high
		Air entrance	Check for air leaks
		Internal wear	Service or replace pump
System vibrations	Defect installation because of resonance or cavitation		
D	Oil overheating beyond 70°C	Max. pressure too high	Check motor
		Oil capacity too low	Fill to correct level
		Insufficient cooling	Check if the rpm of the fan is correct
			Check if the radiator is blocked
		Excessive system heat	Defect pump
			Defective motor
			PRV passing
			Cooling fan not working
Low oil level			

MACHINERY DIRECTIVE

(89/392/EEC: amended by 91/386/EEC and 93/68/EEC)

CERTIFICATE OF INCORPORATION

In accordance with article 4(2) and
Annexe 11B of the above directive.

We,

Transairvac International Limited
Unit 12/17 Croft road industrial est
Newcastle
Staffordshire
ST5 0TW
England.

Declare that all Hydraulic Coolers, Pressure Line Filters, Air & Gas Compressors / Vacuum Pumps / Blowers / Booster Packages and Rotary Lobe Pumps Associated Equipment supplied by us, which may include Electric Motors, must be installed in accordance with our installation instructions and must not be put into service until the machinery/system into which they are incorporated has been declared to be in conformity with the Machine Directive.

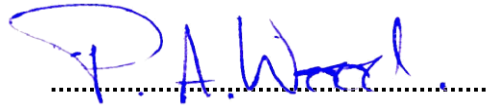

Technical Director